

H&S PARTS BOOK

SW3143 SPREADER



Revision #03
Starting Ser. #717309

Part #72649
HSMFG1216

**P.O. BOX 768, MARSHFIELD, WI 54449
(715) 387-3414 FAX (715) 384-5463
www.hsmfgco.com**

CONTENTS

Instructions for Ordering Parts	1
Figure 1 - Beater and Pan Assembly	2-3
Figure 2 - Hub, Spindle and Box Parts	4-5
Figure 3 - Front Shield and Drive Assembly	6-9
Figure 4 - Back Shield and Drive Assembly	10-13
Figure 5 - Hydraulic Endgate	14-15
Figure 6 - Apron Chain Assembly	16-17
Figure 7 - Worm Gearbox Assembly	18-19
Figure 8 - Bevel Gearbox	20-21
Figure 9 - Hydraulic Cylinder	22
Figure 10 - PTO	23
Figure 11 - Optional Second Beater	24
Figure 12 - Optional Hydraulic Drive Assembly	25
Figure 13 - Optional Electric Control for Hydraulic Drive	26-27
Figure 14 - Electric Control for Hydraulic Drive	28-29
Parts Notes	30

INSTRUCTIONS FOR ORDERING PARTS

All service parts should be ordered through your authorized H&S dealer. They will be able to give you faster service if you will provide them with the following

1. Model & Serial number is located in the front center of the Manure Spreader.
2. All reference to left or right apply to the Manure Spreader as viewed from the rear.
3. Parts should not be ordered from illustration only. Please order by complete part number.
4. If your dealer has to order parts - give shipping instructions:

VIA truck - large pieces (please specify local truck lines)

VIA United Parcel Service (include full address)

H&S MFG. CO. INC.	
MARSHFIELD, WIS.	
MOD. NO.	<input type="text"/>
SER. NO.	<input type="text"/>
DESCR.	<input type="text"/>

PLEASE RECORD NUMBERS FOR YOUR UNIT FOR QUICK REFERENCE

ABOUT IMPROVEMENTS

H&S IS CONTINUALLY STRIVING TO IMPROVE IT'S PRODUCTS

We must therefore, reserve the right to make improvements or changes whenever it becomes practical to do so without incurring any obligation to make changes or additions to the equipment previously sold.

FIGURE 1
BEATER & PAN ASSEMBLY

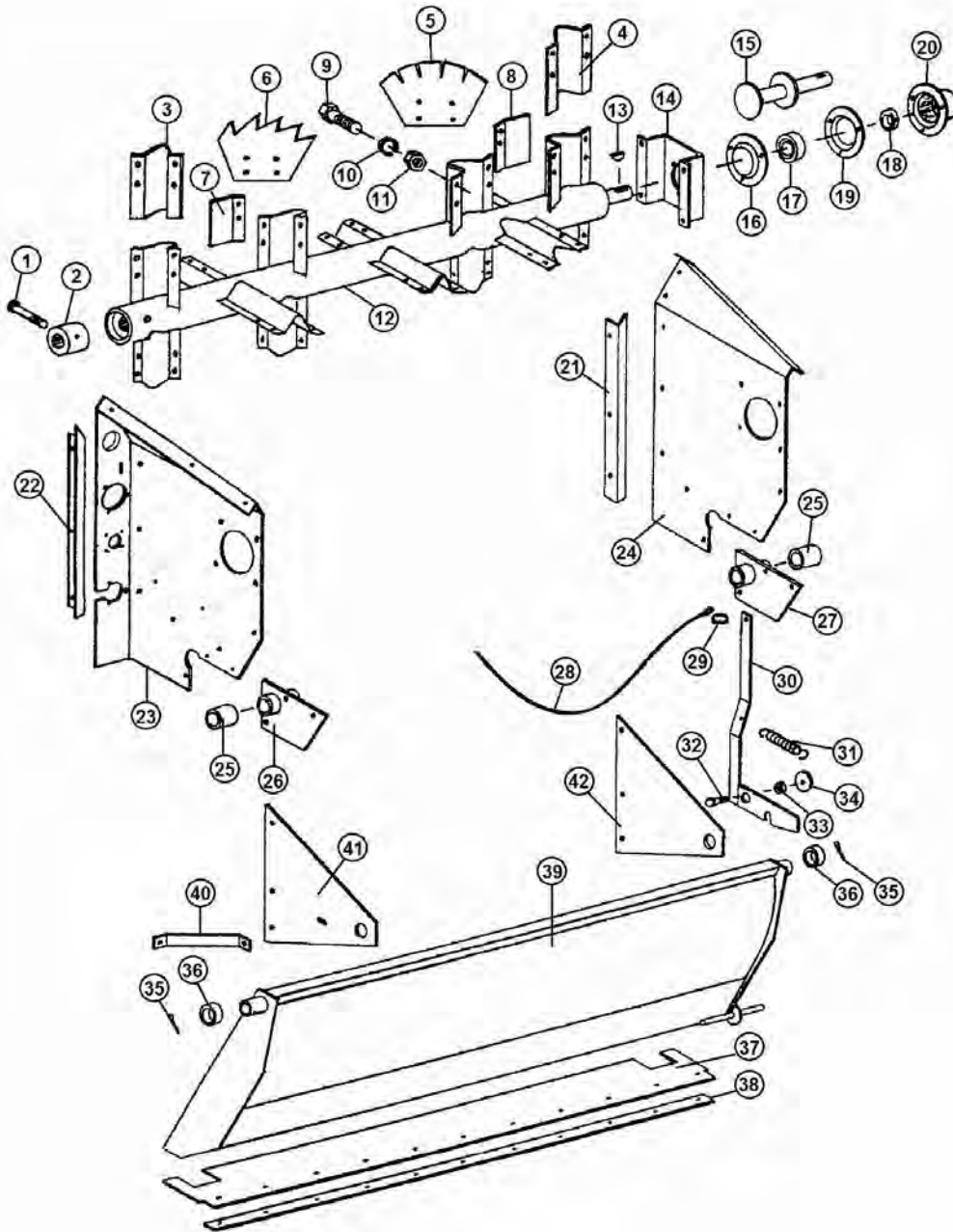

FIGURE 1

BEATER & PAN ASSEMBLY

<u>ITEM</u>	<u>PART #</u>	<u>DESCRIPTION</u>
1	YBHH10130	BOLT, 5/16" X 5" GR. 5
2	43NW1	SPLINED BEATER INSERT
3	23N3	BEATER BLADE HOLDER LH
4	23N4	BEATER BLADE HOLDER RH
5	23N276	BEATER BLADE - HARDENED
6	23N277	BEATER BLADE - HARDENED
7	23N7	BEATER BLADE WIPER LH
8	23N8	BEATER BLADE WIPER RH
9	YBHH16045	BOLT, 1/2" X 1-1/4" GR. 5
10	YWLO16005	WASHER, LOCK, 1/2"
11	YNTL16005	HEX NUT, TOP LOCK, 1/2"-13
12	43NW2	BEATER
13	5B9	3/8" X 1-1/4" WOODRUFF KEY
14	23N10	BEATER SHAFT SUPPORT
15	23N11	BEATER STUB SHAFT
16	F116	BEARING FLANGE (HEAVY DUTY)
17	12N122	BEARING 1-1/4 GREASABLE (FH206-20)
18	12N122	BEARING 1-1/4 GREASABLE (FH206-20)
19	F114A	FLANGE, 1-1/4" W/45 DEG. ZERK
20	23N12	BEARING FLANGE GUARD
21	37N1	RH SIDE POLY HOLD DOWN
22	37N2	LH SIDE POLY HOLD DOWN
23	43NW3	LH MAIN PANEL
24	37N4	RH MAIN PANEL
25	23N17	DRIVE SHAFT BUSHING
26	56245	DRIVE SHAFT BRACKET LH
27	56268	DRIVE SHAFT BRACKET RH
28	37N5	PAN TRIP ROPE
29	R31	CLIP
30	23N21	PAN TRIP LEVER
31	R27	SPRING
32	YBCR16010	CARR. BOLT, 1/2" X 1-1/2" GR. 5
33	23N23	TRIP LEVER SPACER
34	YWFL16005	WASHER, FLAT, 1/2" USS
35	YPCT06020	COTTER PIN, 3/16" X 2"
36	F112	SPACER
37	23N24	PAN RUBBER FLAP
38	23N25	PAN STRAP
39	23N30	PAN
40	23N267	PAN SUPPORT BRACE
41	43NW4	LH PAN SUPPORT
42	23N29	RH PAN SUPPORT

FIGURE 2

HUB, SPINDLE & BOX PARTS

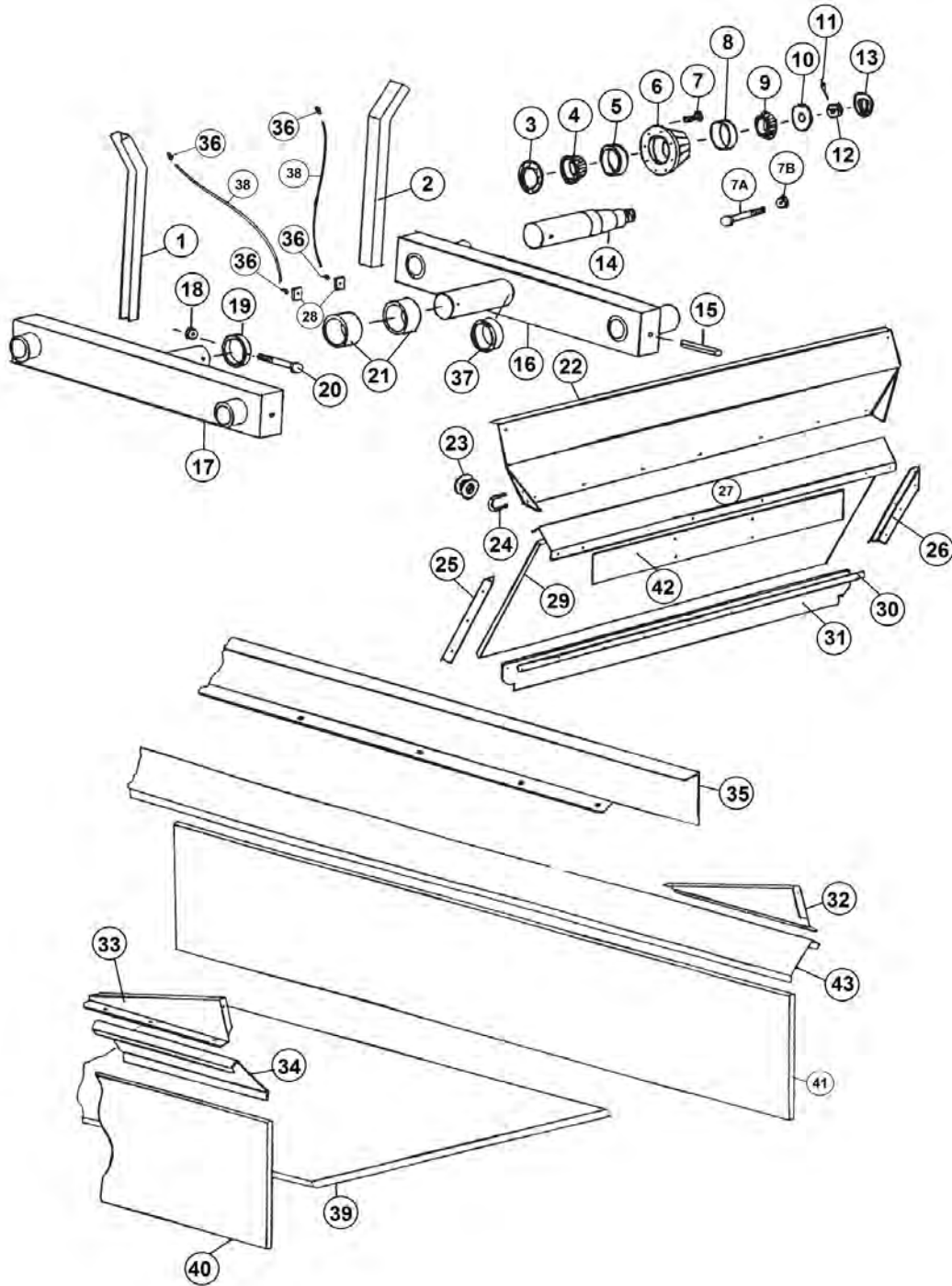

FIGURE 2

HUB, SPINDLE AND BOX PARTS

<u>ITEM</u>	<u>PART #</u>	<u>DESCRIPTION</u>
1	37N6	ASSY, RH SIDE STAKE
2	37N7	ASSY, LH SIDE STAKE
3	B90	GREASE SEAL 260
4	B91	BEARING, INNER
5	B91A	RACE, INNER 260
6	26G4A	HUB ASSEMBLY
7A	YBSD20005	STUD BOLT 5/8-18 UNF X 2 1/4
7B	YNWL20005	WHEEL NUT, 5/8"-18 UNF
8	B94A	OUTER RACE
9	B94	OUTER BEARING
10	YWFL28010	WASHER, FLAT, SAE 7/8 IN
11	YPCT05020	COTTER PIN, 5/32 X 1-3/4
12	NSL28005	HEX NUT, SLOTTED, 7/8-14
13	B2	HUB CAP
14	37N8	SPINDLE FOR 8 X 20 WHEEL
*	16SV203	SPINDLE 2-1/2 X 18-1/2 FOR 821 HUB
15	YPEX16020	EXPANSION PIN, 1/2" X 4"
16	37N85	LH AXLE
17	37N84	RH AXLE
18	YNTL16005	HEX NUT, TOP LOCK, 1/2-13
19	37N86	RING
20	YBHH16150	BOLT, 1/2"-13 X 4-3/4" GR 5
21	B58	BUSHING FOR TANDEM AXLE
22	23N34	FRONT FLARE
23	F33	SIDE CABLE GUIDE
24	YBPU08005	PIPE U BOLT, 1/4 X 3/4
25	37N12	PLYWOOD ANGLE RH
26	37N13	PLYWOOD ANGLE LH
27	23N176	FRONT END BRACE
28	16V9	GREASE ZERK BRACKET
29	37N65	POLY PLYWOOD, FRONT GATE, 7 PLY - 5/8" X 26-1/2" X 59-3/4"
30	23N40	STRAP FOR RUBBER
31	23N41	FRONT GATE RUBBER
32	23N42	SPLASH GUARD LEFT
33	23N43	SPLASH GUARD RIGHT
34	43N3	SIDE FLARE RH
35	43N1	SIDE EXTENSION LH
36	S47	GREASE LINE FITTING
37	B111	AXLE BEARING
38	31N43	GREASE LINE
39	37N81	SOLID POLY FLOOR - 370-430
40	37N67	BONDED POLY/PLYWOOD SIDE (RH)
41	37N68	BONDED POLY/PLYWOOD SIDE (LH)
42	37N51	FRONT PANEL
43	43N4	LH SIDE FLARE
*	12V36	WHEEL, 16.1 X 14, 8 BOLT
*	23N179A	WHEEL, 8.25 X 22.5, 8 BOLT

*MEANS NOT SHOWN

FIGURE 3

FRONT SHIELD & DRIVE ASSEMBLY

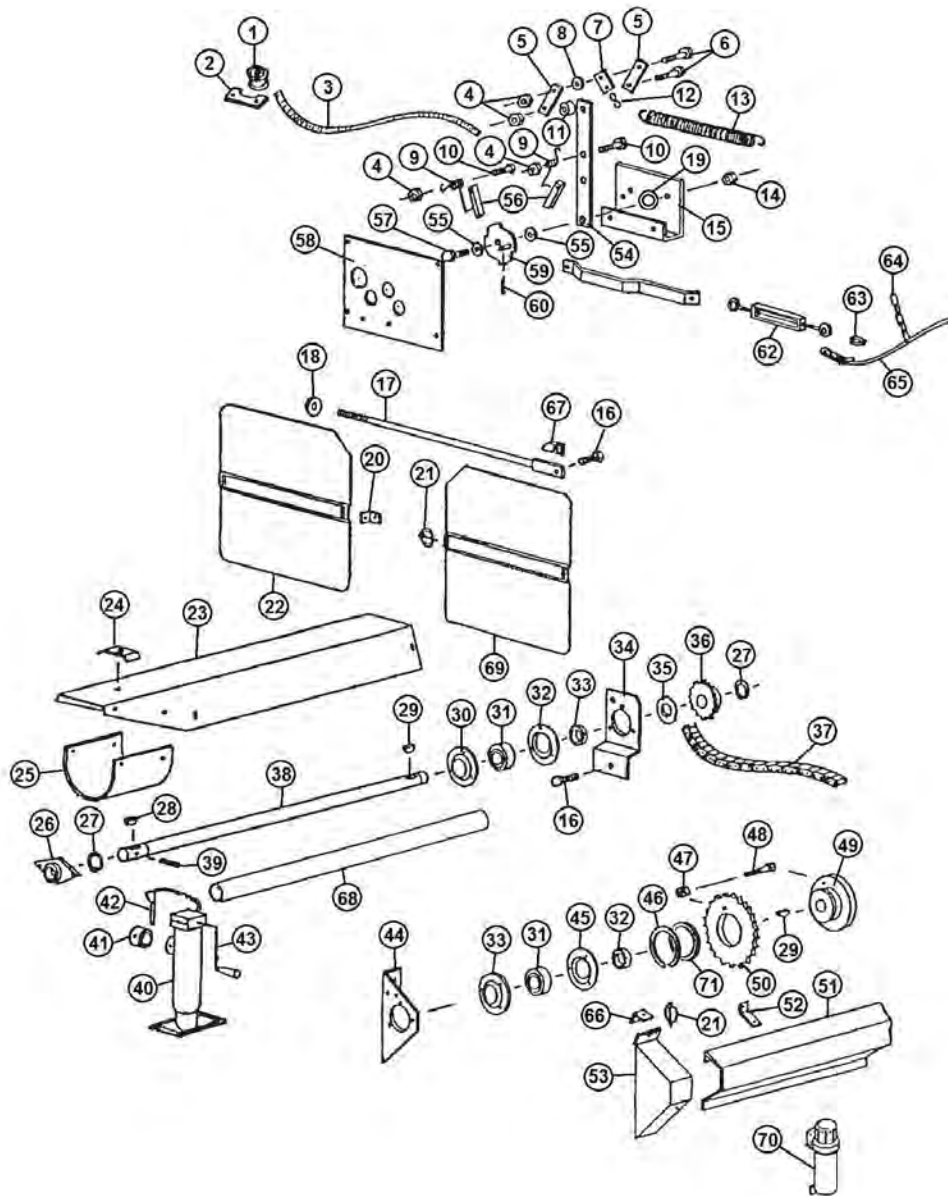

FIGURE 3

FRONT SHIELD & DRIVE ASSEMBLY

<u>ITEM</u>	<u>PART #</u>	<u>DESCRIPTION</u>
1	F33	CABLE GUIDE
2	23N182	BRACKET
3	23N183	ROPE - 15'
4	YNTL12005	HEX NUT, TOP LOCK, 3/8"-16
5	23N184	BRACKET
6	YBHH12035	BOLT, 3/8" X 1-1/4" GR. 5
7	23N185	SPRING BRACKET
8	YWFL12005	WASHER, FLAT, 3/8" USS
9	23N186	DOG SPRING
10	YBHH12010	BOLT, 3/8" X 1" GR. 5
11	D107	SPACER
12	X79	S-HOOK
13	23N187	SPRING
14	YNHX16005	HEX NUT, 1/2"
15	23N188	SHIFTER BRACKET
16	YBHH16045	BOLT, 1/2" X 1-1/4" GR. 5
17	23N63	TIGHTENER ROD
18	F129	WASHER
19	31N51	SHIFTER SPACER WASHER
20	F92	SHIELD BRACKET
21	YPLY08010	LYNCH PIN, 1/4" X 1-1/2"
22	23N305	FRONT SHIELD
23	23N66	SHIELD
24	23N67	TAILGATE HOSE BRACKET
*	HE42	HYDRAULIC DRIVE BRACKET SHIELD
25	F54	BEARING
26	12N29	SNAP RING
27	F73	1/4" X 1" KEY
28	5B10	3/8" X 1-1/4" KEY
29	5B9	FLANGE, 1-1/4" W/45 DEG. ZERK
30	F114A	BEARING W/LOCK COLLAR
31	12N122	ASSEMBLY BEARING W/LOCK COLLAR
32	12N122	ASSEMBLY BEARING
33	F14	FLANGE, BEARING, 4.44 OD, 2.24
34	23N68	JACK SHAFT BRACKET
35	23N69	FRONT SHAFT SPACER
36	43NW5	SPROCKET, 19 TOOTH
*	43NW21	SPROCKET, 11T, (OPTIONAL 1000 RPM)

* MEANS NOT SHOWN

FIGURE 3

FRONT SHIELD & DRIVE ASSEMBLY

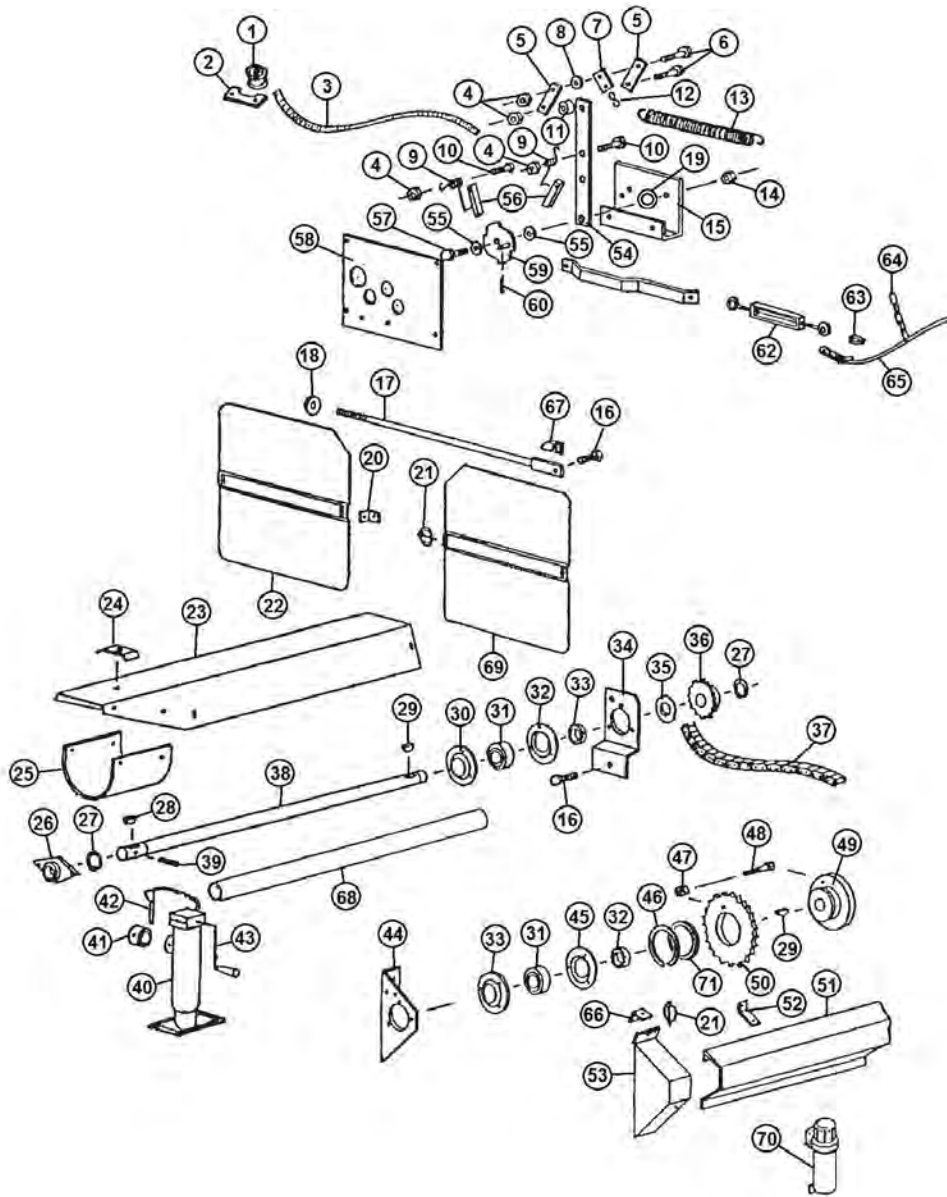

FIGURE 3

FRONT SHIELD & DRIVE ASSEMBLY

<u>ITEM</u>	<u>PART #</u>	<u>DESCRIPTION</u>
37	43NW6	#80 ROLLER CHAIN 92 PITCHES
38	43NW7	FRONT SHAFT
39	YPEX10020	EXPANSION PIN, 5/16" X 2-1/4"
40	27N14	JACK
*	12N9	JACK GEAR REPAIR KIT
41	12N14	JACK MOUNT
42	12N13	JACK PIN
43	12N12	HANDLE
44	23N74	BEARING PLATE
45	F114A	FLANGE
46	23N189	SNAP RING
47	YNTL12005	HEX NUT, TOP LOCK, 3/8"-16
48	YBHH12025	BOLT, 3/8" X 1-1/2" GR. 5
49	45N71	SHEAR HUB
50	45N68	23T SPROCKET
51	37N27	SIDE SHIELD
52	23N79	BRACKET
53	23N80	SHIELD
54	23N192	FRONT SHIFTER ARM
55	YWFL16005	WASHER, FLAT, 1/2" USS
56	23N193	DOG
57	YBHH16055	BOLT, 1/2" X 1-3/4" GR. 5
58	23N195	SHIFTER PANEL
59	23N196	SPEED SELECTOR
60	YPCT04005	COTTER PIN, 1/8" X 1"
61	23N197	SHIFTER ARM
62	F84	TURNBUCKLE
63	F44	CABLE LOOP
64	37N64	CABLE CHAIN
65	37N53	CABLE
66	F92	SHIELD BRACKET
67	23N278	SPACER
68	37N74	FRONT SHAFT GUARD
69	23N306	FRONT SHIELD LH
70	S522	MANUAL HOLDER
71	C112G01	SHEAR HUB SPACER
72	31N51	SHIFTER SPACER WASHER

NOTE: * MEANS NOT SHOWN

FIGURE 4

BACK SHIELDS & DRIVE ASSEMBLY

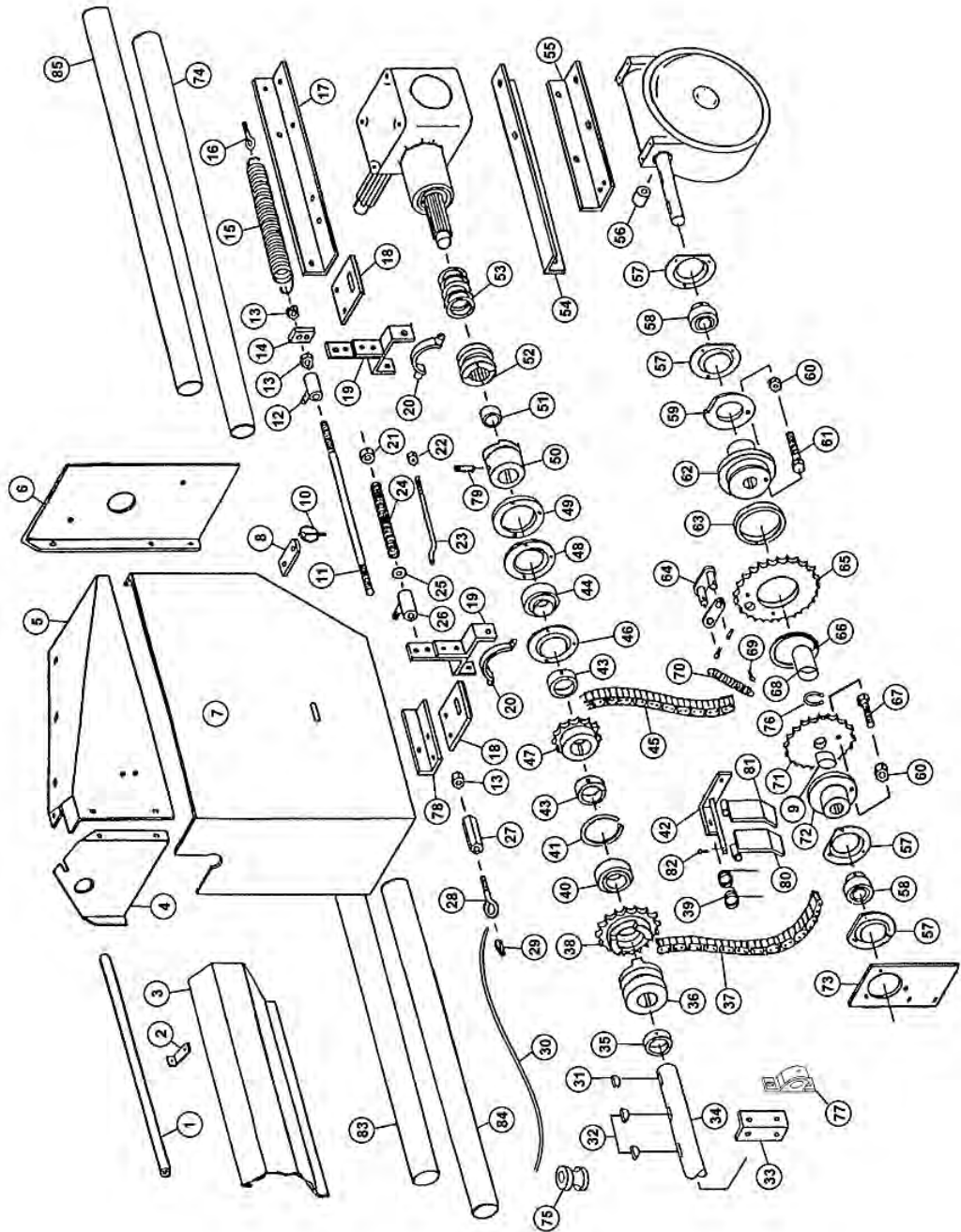

FIGURE 4

BACK SHIELDS & DRIVE ASSEMBLY

<u>ITEM</u>	<u>PART #</u>	<u>DESCRIPTION</u>
1	23N200	CABLE GUARD
2	23N79	SIDE SHIELD BRACKET
3	37N54	SIDE SHIELD
4	43NW10	SHIELD
5	43NW11	BACK SHIELD TOP
6	43NW12	BACK SHIELD
7	43NW13	COVER
8	43NW14	SHIELD BRACKET
9	56027	BUSHING
10	S122	LYNCH PIN, 1/4" X 1-1/2"
11	23N205	CLUTCH ROD
12	23N206	SHIFTING ROD BRACKET
13	YNHX12005	HEX NUT, 3/8"-16
14	23N207	SPRING BRACKET
15	K103	SPRING
16	YBTE10030	TURNED EYE BOLT, 5/16 X 3
17	43NW16	ANGLE
18	23N86	SHIFTER BRACKET
19	D57	SHIFTER LEVER
20	23N208	YOKE W/ ZERK
21	23N209	COLLAR
22	YNTL08005	HEX NUT, TOP LOCK, 1/4"-20
23	23N210	SHIFTING ROD
24	23N211	SPRING BRACKET
25	YWFL12005	WASHER, FLAT, 3/8" USS
26	23N206	ROD BRACKET
27	23N212	COUPLING NUT
28	YBTE12005	TURNED EYE BOLT, 3/8" X 1"
29	F44	CABLE LOOP
30	37N53	CABLE
31	5B9	3/8" X 1-1/4" WOODRUFF KEY
32	5B10	1/4" X 1" WOODRUFF KEY
33	23N97	SIDE BEARING BRACKET
34	43NW19	SIDE SHAFT
35	F6	COLLAR
36	23N215	CLUTCH THROW-OUT
37	23N93	#50 CHAIN 60 PITCHES
38	23N216	CLUTCH SPROCKET
*	61138	INCLUDES (SPROCKET,BEARING,SNAP RING)
39	31N33	SPRING TIGHTENER
40	BFR525	BEARING
41	3G19	SNAP RING
42	31N36	TIGHTENER BRACKET
43	12N122	BEARING W/LOCK COLLAR ASSEMBLY

FIGURE 4

BACK SHIELDS & DRIVE ASSEMBLY

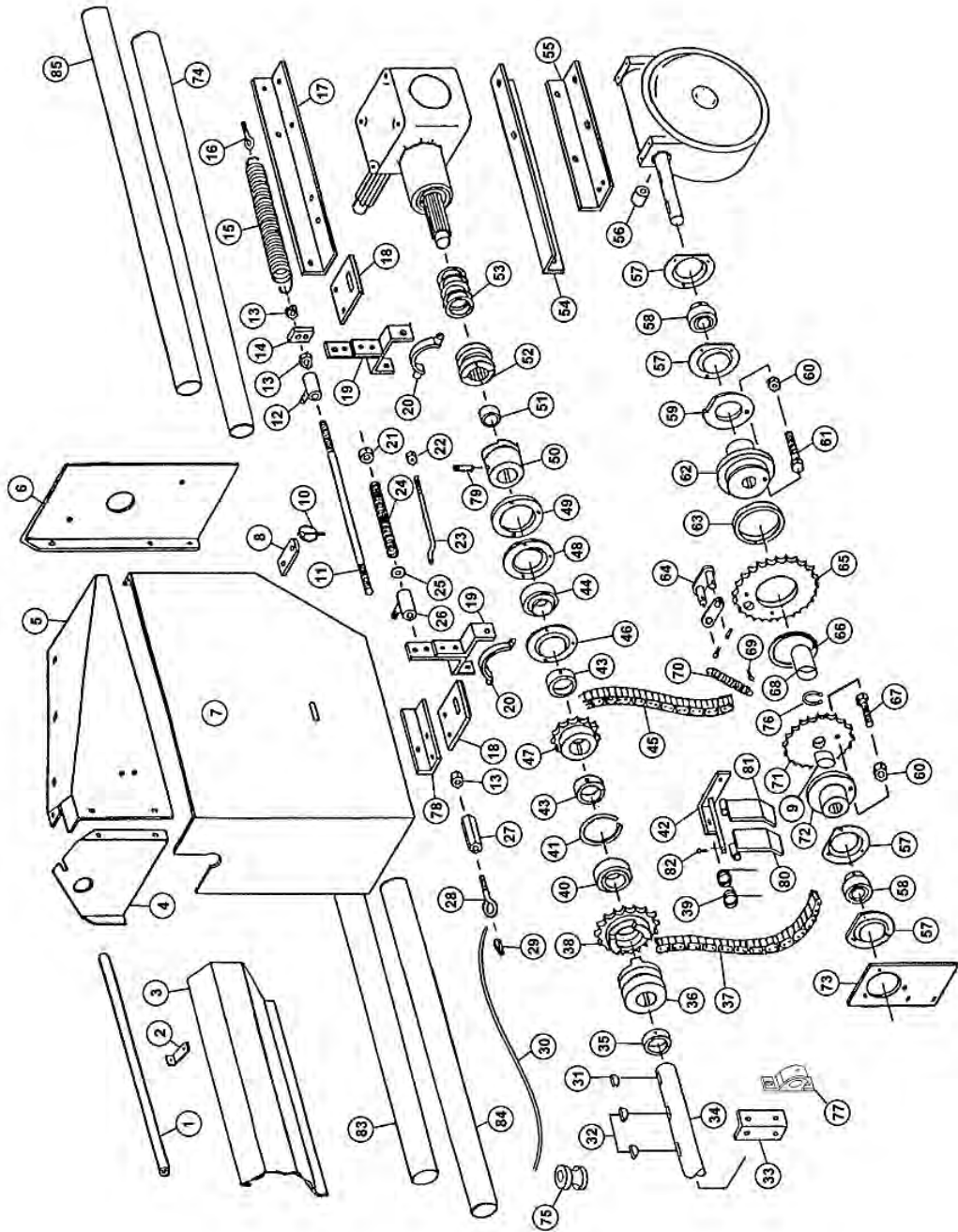

FIGURE 4

BACK SHIELDS & DRIVE ASSEMBLY

<u>ITEM</u>	<u>PART #</u>	<u>DESCRIPTION</u>
44	12N122	BEARING W/LOCK COLLAR ASSEMBLY
45	23N93	#50 CHAIN 60 PITCHES
46	F114A	FLANGE
47	10R11	13 TOOTH SPROCKET
48	F14	FLANGE
49	23N174	FLANGE SPACER
50	23N241	CLUTCH
51	D68	BRONZE BUSHING
52	23N90	CLUTCH
53	43NW17	SPRING
54	43NW18	BOTTOM ANGLE
55	23N95	WORM BOX HOLDER
56	23N94	SPACER
57	X85	FLANGE
58	23N221	BEARING W/ SETSCREWS
59	23N222	SHEAR PLATE
60	YNTL08005	HEX NUT, TOP LOCK, 1/4"-20
61	YBHH08035	BOLT, 1/4" X 1-1/4" GR. 5
62	23N224	SHEAR HUB
63	23N225	BUSHING, BRONZE
64	60531	CONNECTOR LINK W/ PINS
65	74381	SPKT, 50, A, 30
*	23N226	SPKT ASSY, 50, A, 30, WITH BSH
66	23N227	SNAP RING
67	YBHH08035	BOLT, 1/4" X 1-1/4" GR. 5
68	23N228	SPACER
69	YPCT04005	COTTER PIN, 1/8" X 1"
70	23N229	DOG SPRING
71	D64	25T SPROCKET
72	D63	SHEAR HUB
73	23N230	BEARING PANEL
74	60644	#4 SIDE SHAFT GUARD
75	F33	CABLE GUIDE
76	56024	EXTERNAL SNAP RING 1-1/2"
77	12N36	BRG, PILLOW BLOCK 1.25IN
78	23N239	SHIFTER SUPPORT
79	YSFD12005	SET SCREW, SOCKET, FULL DOG PT, 3/8"-16
80	31N34	X 3/4" LH TIGHTENER BAR
81	31N35	RH TIGHTENER BAR
82	YPCT04005	COTTER PIN, 1/8" X 1"
*	X60	#50 OFFSET
*	X61	#50 CONN.
*	31N38	CHAIN TIGHTENER ASSEMBLY
83	37N76	#2 SIDE SHAFT GUARD
84	37N75	#1 SIDE SHAFT GUARD
85	37N76	#2 SIDE SHAFT GUARD

NOTE: * MEANS NOT SHOWN

FIGURE 5

HYDRAULIC ENDGATE ASSEMBLY

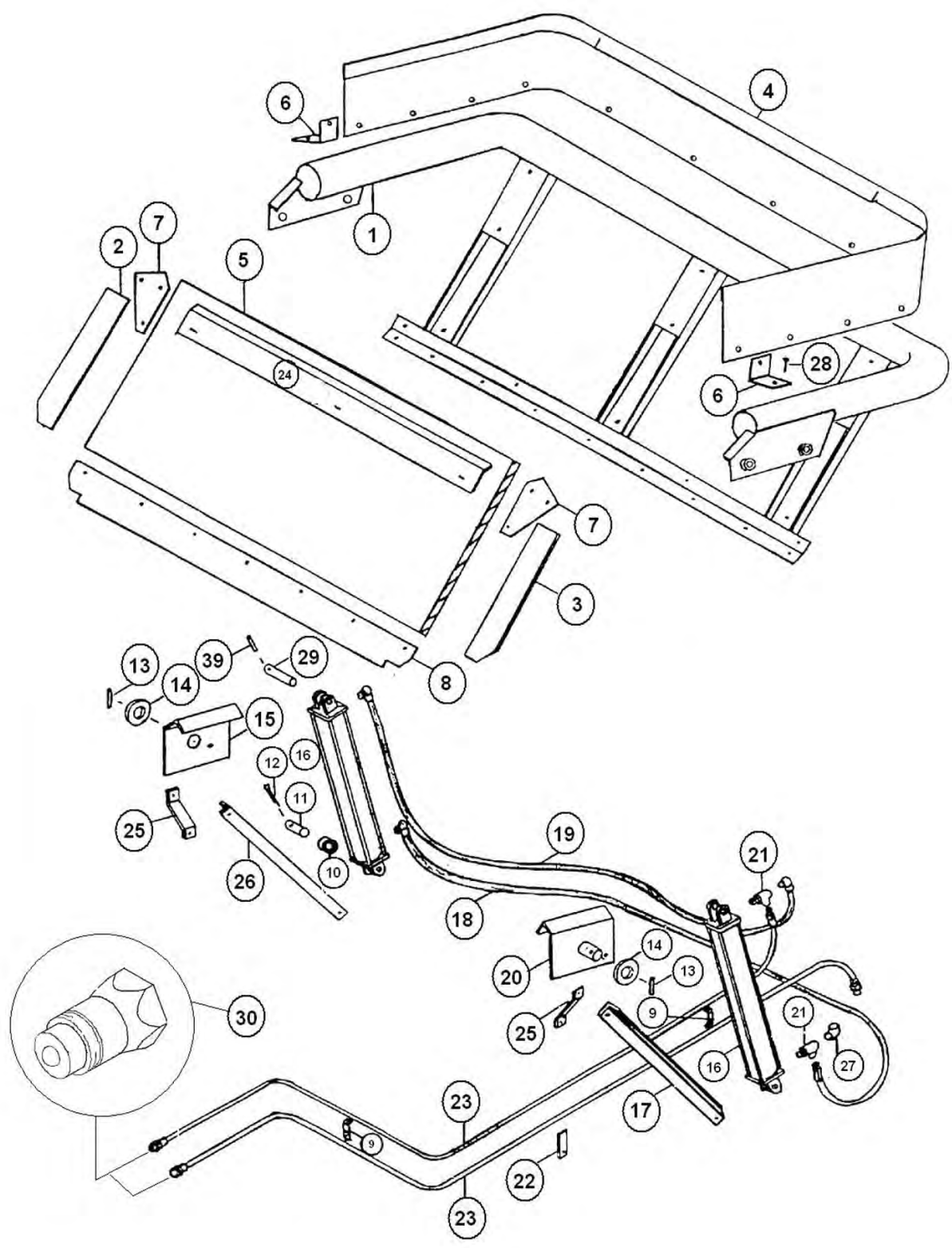

FIGURE 5

HYDRAULIC ENDGATE ASSEMBLY

<u>ITEM</u>	<u>PART #</u>	<u>DESCRIPTION</u>
1	37N34	TAILGATE FRAME
2	37N35	RH SIDE RUBBER
3	37N36	LH SIDE RUBBER
4	43N5	BACK EXTENSION
5	37N69A	TAILGATE PLYWOOD WITH FIBERGLASS
6	43N6	EXTENSION ANGLE
7	23N104	TAILGATE CORNER
8	23N105	BOTTOM RUBBER
9	23N67	HOSE BRACKET
10	K132	SPACER
11	23N107	CYLINDER PIN
12	YPCT07005	COTTER PIN, 7/32" X 2 "
13	YPEX10015	EXPANSION PIN, 5/16" X 1-3/4"
14	23N109	WASHER
15	23N110	RH TAILGATE MOUNT
16	23N111A	HYDRAULIC CYLINDER(SERIAL #417213 AND PRIOR)
*	56015	2" x 16" HYDRAULIC CYLINDER(SERIAL #417214 AND FORWARD)
17	37N59	BRACE
18	37N60	HOSE (23N113-96" / 37N60-108")
19	37N61	HOSE (23N114-138" / 37N61-152")
20	23N115	LH TAILGATE MOUNT
21	23N116	TEE
22	23N117	HOSE HOLDER
23	37N83	HOSE 328"
24	23N163	TAILGATE POLY HOLD DOWN
25	23N232	TAILGATE BRACKET BRACE
26	37N62	TAILGATE BRACKET BRACE
27	23N234	90° STREET ELBOW 3/8"
28	12V3	SELF TAPPING BOLT
29	23N301	CYLINDER PIN
30	DWM205	MALE QUICK COUPLER

FIGURE 6

APRON CHAIN ASSEMBLY

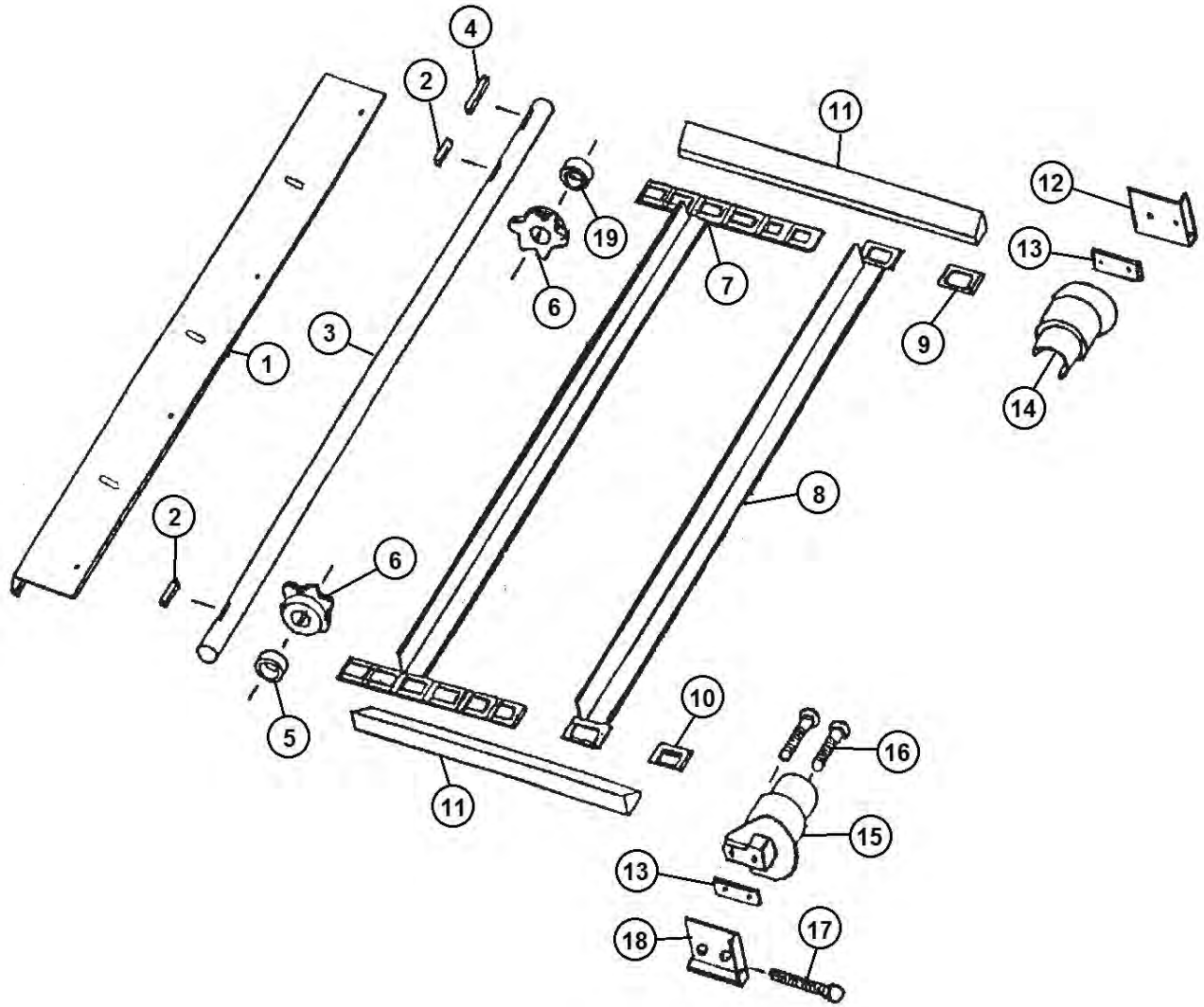

FIGURE 6

APRON CHAIN ASSEMBLY

<u>ITEM</u>	<u>PART #</u>	<u>DESCRIPTION</u>
1	23N119	REAR POLY HOLDOWN
2	23N303	3/8" X 1-3/4" SQUARE KEY
3	27N19	DRIVE SHAFT
4	S138	3/8" X 2-3/8" SQUARE KEY W/ ROUND ENDS
5	23N121	SPACER 5/8"
6	23N122	DRIVE SPROCKET 6T
7	37N42	APRON CHAIN 28 SLATS, 280 LINKS
8	23N124	SLAT W/ ATTACHMENT LINKS
9	S55	T-ROD STANDARD LINK
10	S56	T-ROD CONNECTOR LINK
11	37N43	APRON CHAIN SIDE SPACERS
12	A30	CHAIN SLIDE PLATE LH
13	23N126	CHAIN SLIDE SPACER
14	23N127	T-ROD SLIDE LH
15	23N128	T-ROD SLIDE RH
16	YBCR16045	CARR. BOLT, 1/2" X 4" GR. 5
17	YBHH16145	BOLT, 1/2" X 4-1/2" GR. 5 FULL THREAD
18	A29	CHAIN SLIDE PLATE RH

FIGURE 7
WORM GEARBOX ASSEMBLY

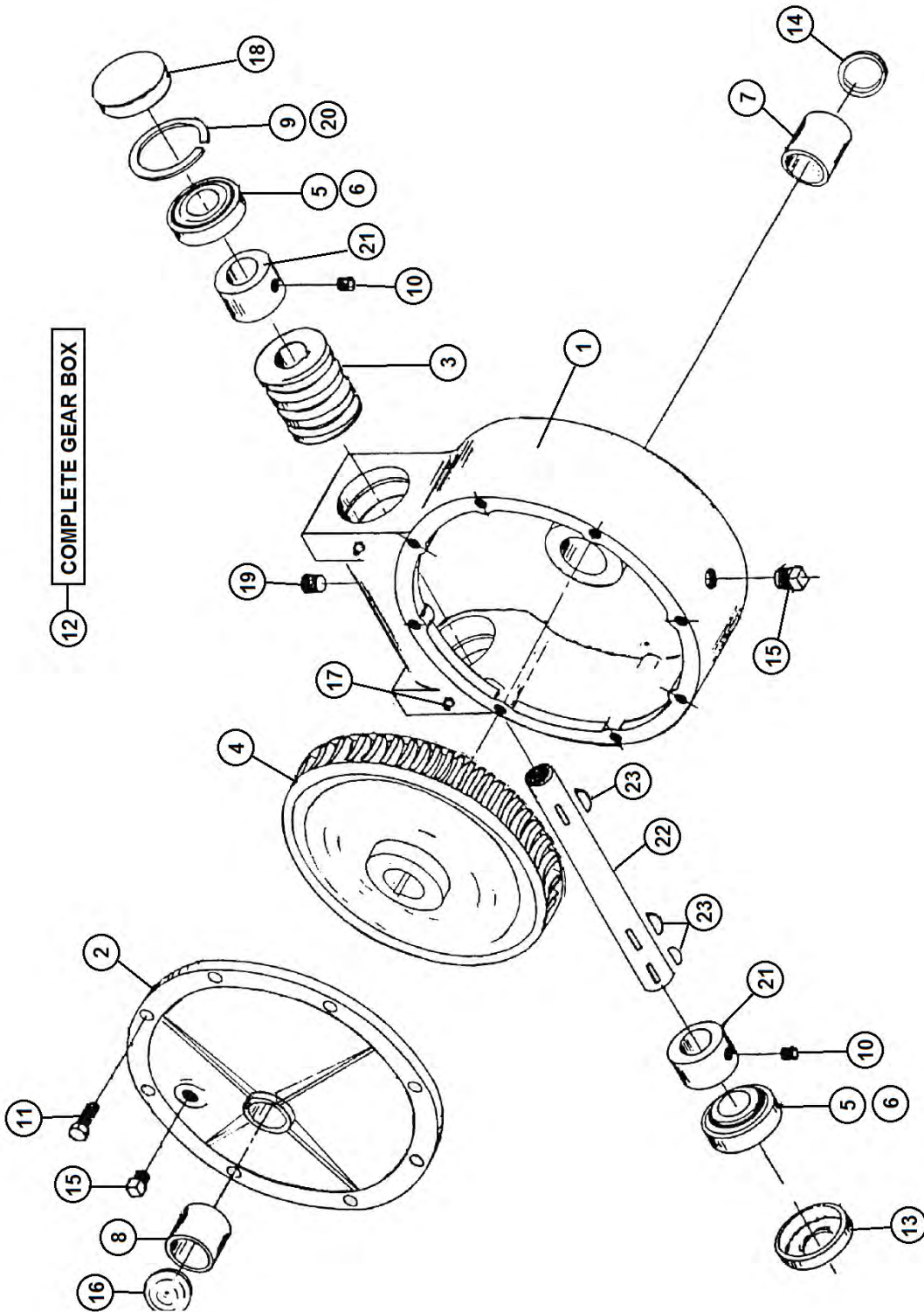

FIGURE 7

WORM GEARBOX ASSEMBLY

<u>ITEM</u>	<u>PART #</u>	<u>DESCRIPTION</u>
1	G114	HOUSING
2	G116	COVER
3	G76	WORM
4	G77	WORM GEAR
5	G78	BEARING #15101
6	G79	BEARING CUP #15245
7	X8	BEARING - OIL LITE
8	X75	BEARING - OIL 1 1/2 X 1 3/4 X 1 1/4
9	G82	SNAP RING
10	YSKP12025	SET SCREW, SOCKET, KNURLED CUP PT, 3/8"-16 X 3/8"
11	YSKP12005	SET SCREW, SOCKET, KNURLED CUP PT, 3/8"-16 X 1"
12	G122	WORM GEARBOX COMPLETE
13	G123	SEAL
14	17G133	SEAL
15	G65	PLUG 3/8" NPT
16	G117	CAP 1-7/8"
17	G89	ZERK 1/4"-28
18	G90	CAP
19	G91	VENT PLUG 3/8" NPT
20	G92	SHIM
21	G93	SPACER
22	23N236	WORM GEAR SHAFT
23	5B10	1/4" X 1" WOODRUFF KEY
*	G88	GASKET

*** MEANS NOT SHOWN**

FIGURE 8

BEVEL GEARBOX

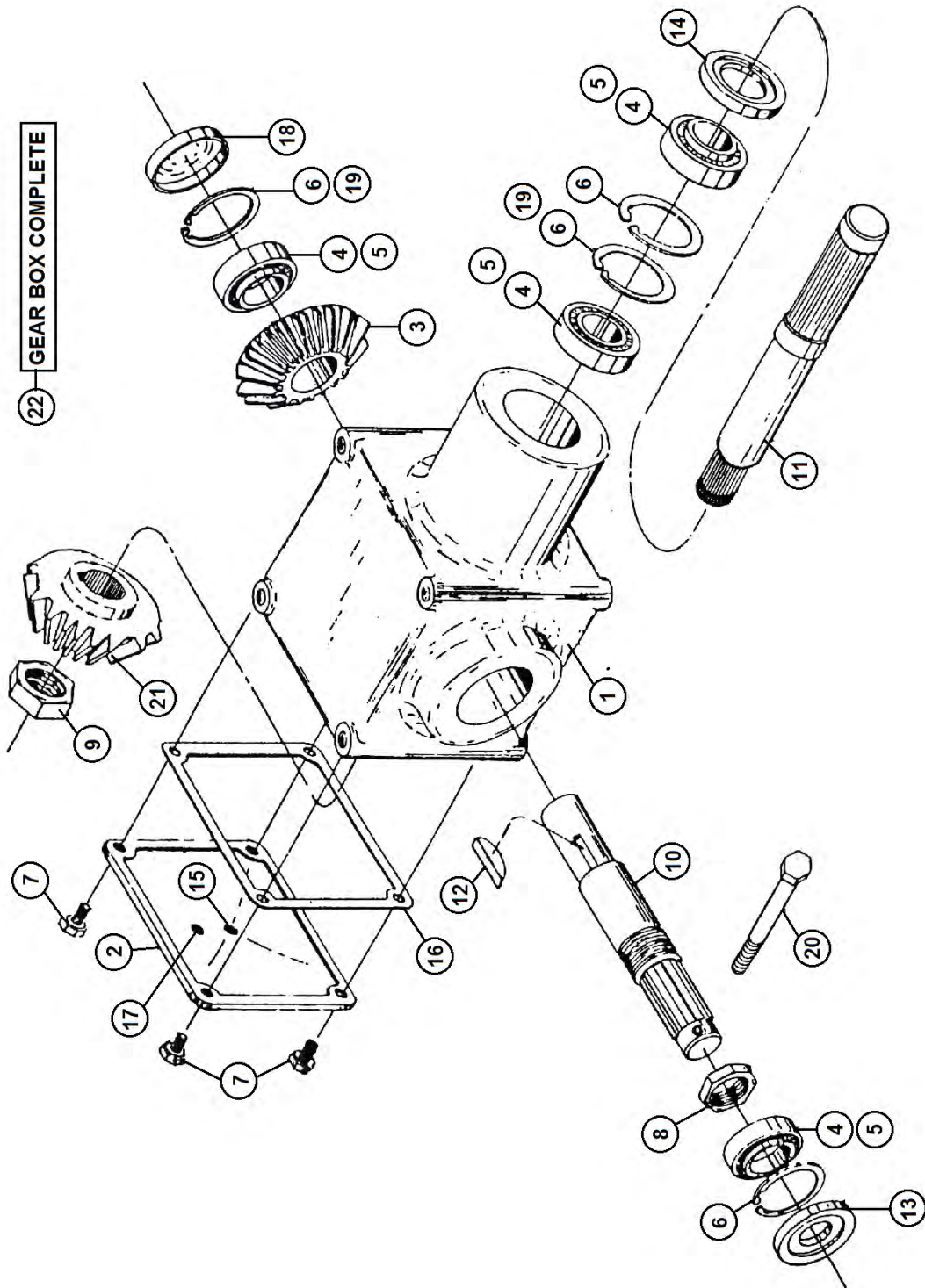

FIGURE 8

BEVEL GEARBOX

<u>ITEM</u>	<u>PART #</u>	<u>DESCRIPTION</u>
1	G125	HOUSING
2	G126	COVER
3	G127	BEVEL GEAR 33T
4	G128	BEARING CUP #25520
5	G129	BEARING CONE #25581
6	G130	SNAP RING
7	G131	CAPSCREW
8	G132	STAKE NUT
9	G133	STAKE NUT
10	G134	SHAFT - OUTPUT
11	G135	SHAFT - INPUT
12	G61	"E" (1210) WOODRUFF KEY (HARD)
13	G136	SEAL - OUTPUT
14	G137	SEAL - INPUT
15	G65	PLUG 3/8" NPT
16	G138	GASKET
17	G139	KEY 3/8" SQ. X 1-1/2" - HARD
18	G140	CAP
19	G141	SHIM
20	YBHH10130	BOLT, 5/16" X 5" GR. 5
21	G142	BEVEL GEAR 22T - SPLINED
22	G143	BEVEL GEARBOX COMPLETE
23	G144	VENT PLUG
24	G145	PLUG

FIGURE 9

HYDRAULIC CYLINDER

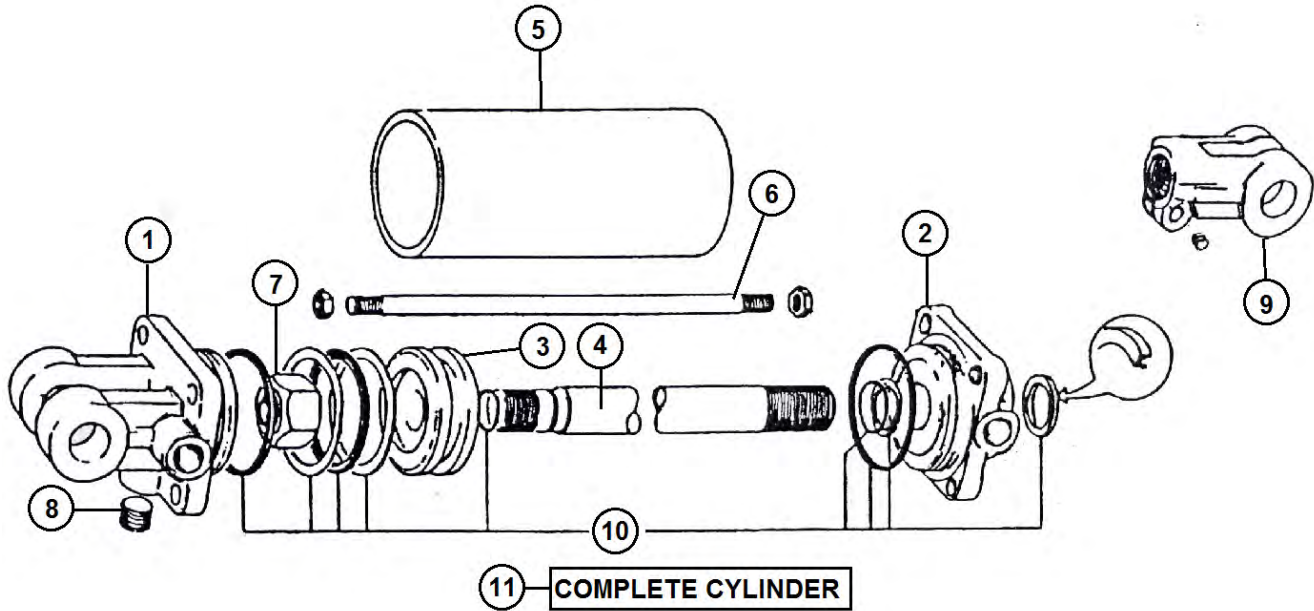

<u>ITEM</u>	<u>PART #</u>	<u>DESCRIPTION</u>
1	23N142A	CLEVIS CAP
2	23N143A	ROD CAP
*	56174	ROD CAP FOR 2" CYLINDER
3	23N144	PISTON
*	56180	PISTON FOR 2" CYLINDER
4	23N145A	ROD CAP
5	23N146	CYLINDER TUBE
6	23N147	TIE ROD
7	23N148	PISTON NUT
8	23N149	PLUG
9	23N150A	ROD CLEVIS
10	23N151	SEAL KIT
*	56187	SEAL KIT FOR 2" CYLINDER
11	23N111A	HYDRAULIC CYLINDER
*	56015	2" X 16 HYDRAULIC CYLINDER

FIGURE 10

PTO ASSEMBLY

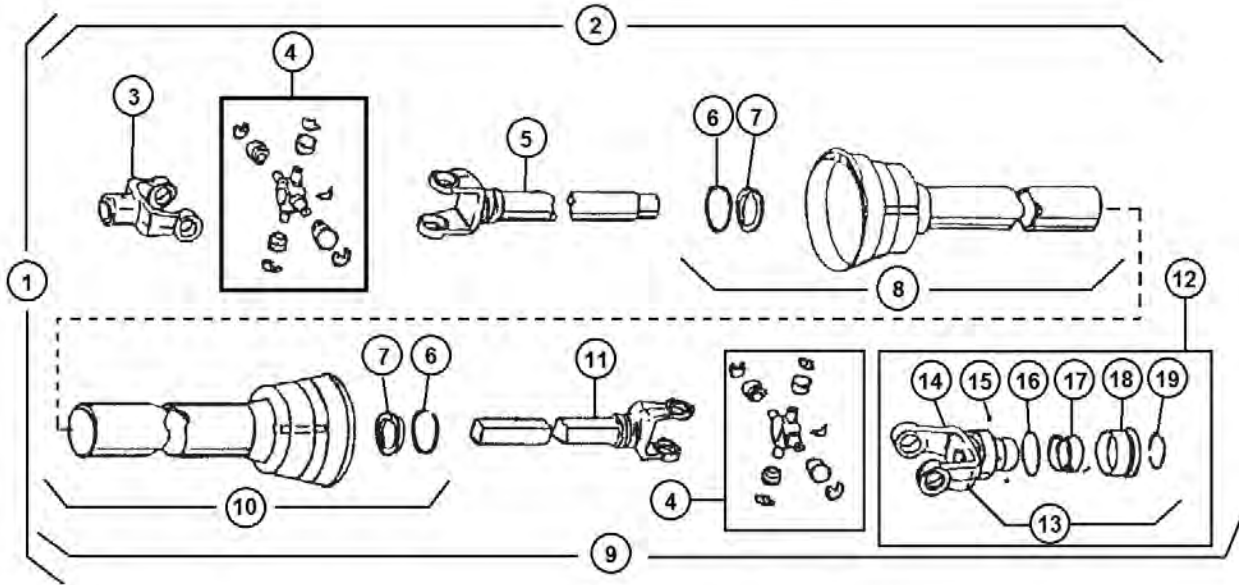

<u>ITEM</u>	<u>540 RPM</u>	<u>1000 RPM</u>	<u>DESCRIPTION</u>
1	23N152	23N313	PTO COMPLETE W/SHIELDS
2	23N153	"	MACHINE HALF PTO W/SHIELDS
3	G1R35	"	END YOKE MACHINE HALF
4	14NWKIT	"	REPAIR KIT
5	23N155	"	YOKE AND TUBE
6	24N26	"	BEARING RETAINER
7	4N20	"	NYLON BEARING
8	23N156	"	INNER GUARD INCLUDING ITEM #6 & #7
9	23N157	23N314	TRACTOR HALF PTO W/SHIELD
10	23N158	23N315	OUTER GUARD INCLUDING ITEM #6 & #7
11	23N159	"	YOKE AND SHAFT
12	23N162	"	LOCK YOKE ASSEMBLY
*	37N73	"	OPTIONAL 1000 RPM YOKE (1-3/8")
13	S225	"	SPRING LOCK REPAIR KIT
14	S226	"	COVER
15	S212	"	STAINLESS BALL
16	S227	"	WASHER
17	S228	"	SPRING
18	S229	"	COLLAR ASSEMBLY
19	S215	"	RETAINING RING
*	S402	"	PTO SAFETY MANUAL

* MEANS NOT SHOWN

" MEANS SAME # AS PREVIOUS MODEL

FIGURE 11

OPTIONAL 2ND BEATER

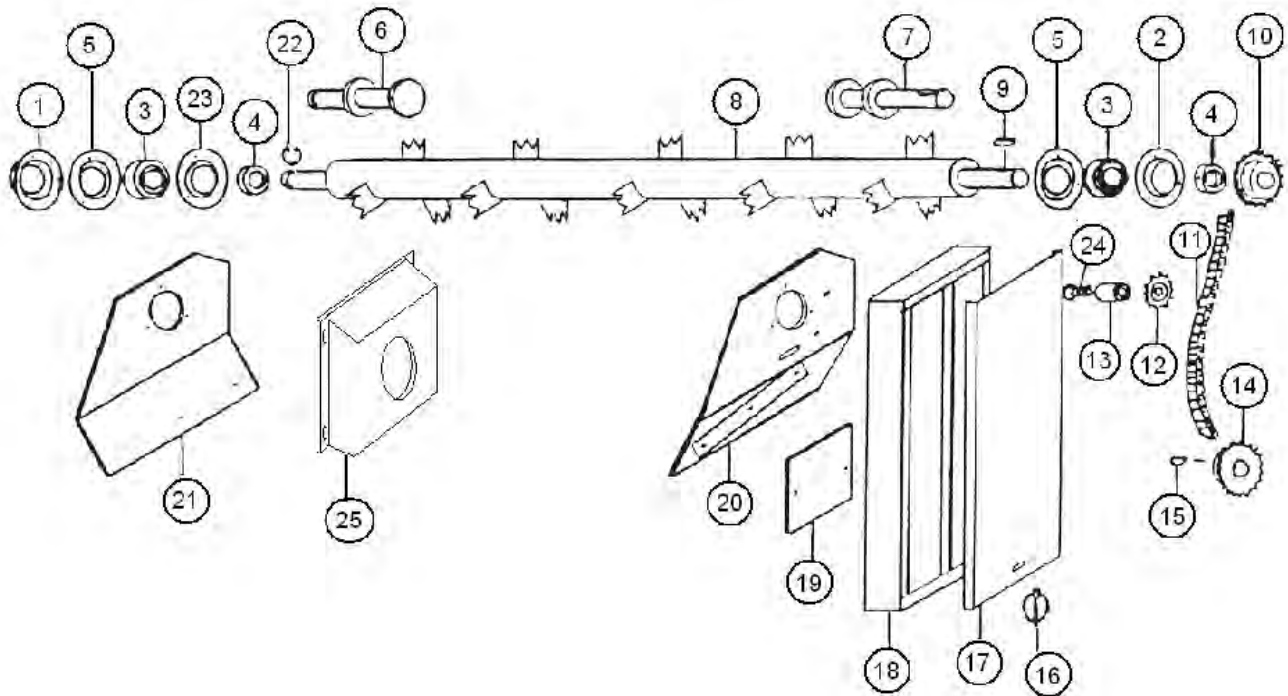

<u>ITEM</u>	<u>PART #</u>	<u>DESCRIPTION</u>
1	F95	BEARING FLANGE GUARD
2	F114	BEARING FLANGE W/ ZERK
3	F115	BEARING
4	F14	BEARING FLANGE
5	F16	LOCK COLLAR
6	23N164	LH STUB SHAFT
7	23N165	RH STUB SHAFT
8	23N166	2ND BEATER
9	G23	5/16" X 1-3/8" SQUARE KEY
10	37N71	SPROCKET
11	37N49	#60 CHAIN
12	12N42	IDLER SPROCKET
14	37N70	SPROCKET
15	5B9	3/8" X 1-1/4" KEY
16	YPLY08010	LYNCH PIN, 1/4" X 1-1/2"
17	23N169	COVER
18	37N48	SHIELD
19	37N45	SHIELD
20	37N46	RH PANEL
21	37N47	LH PANEL

FIGURE 12

OPTIONAL HYDRAULIC DRIVE ASSEMBLY

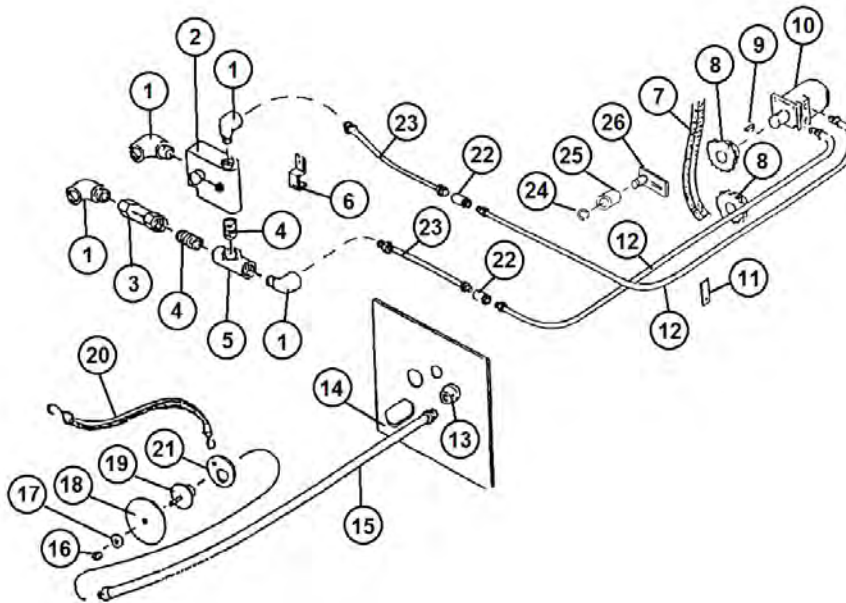

<u>ITEM</u>	<u>PART #</u>	<u>DESCRIPTION</u>
1	HE58	90° STREET ELBOW
2	DF15	SPEED CONTROL
3	DF18	CHECK VALVE
4	DF7	NIPPLE
5	DF8	TEE
6	HE14	HOSE BRACKET
7	23N131	#50 CHAIN 40 PITCHES
8	11S19	20T SPROCKET
9	5B10	1/4" X 1" WOODRUFF KEY
10	DF1	HYDRAULIC MOTOR
11	23N117	HOSE HOLDER
12	23N132	HYDRAULIC MOTOR HOSE
13	DF21	REDUCER
14	23N133	CONTROL PANEL
15	DF9	HOSE FOR HANDLE
16	YNTL12005	HEX NUT, TOP LOCK, 3/8"-16
17	DF12	WASHER
18	DF11	HANDLE
19	DF10	HANDLE BRACKET
20	DF14	STRAP
21	DF22	RING FOR STRAP
22	31N23	COUPLING
23	HE12	HOSE
24	10R32	SNAP RING
25	23N238	CHAIN TIGHTENER ROLLER
26	L10R35	TIGHTENER BRACKET

FIGURE 13
OPTIONAL ELECTRIC CONTROL FOR HYDRAULIC DRIVE

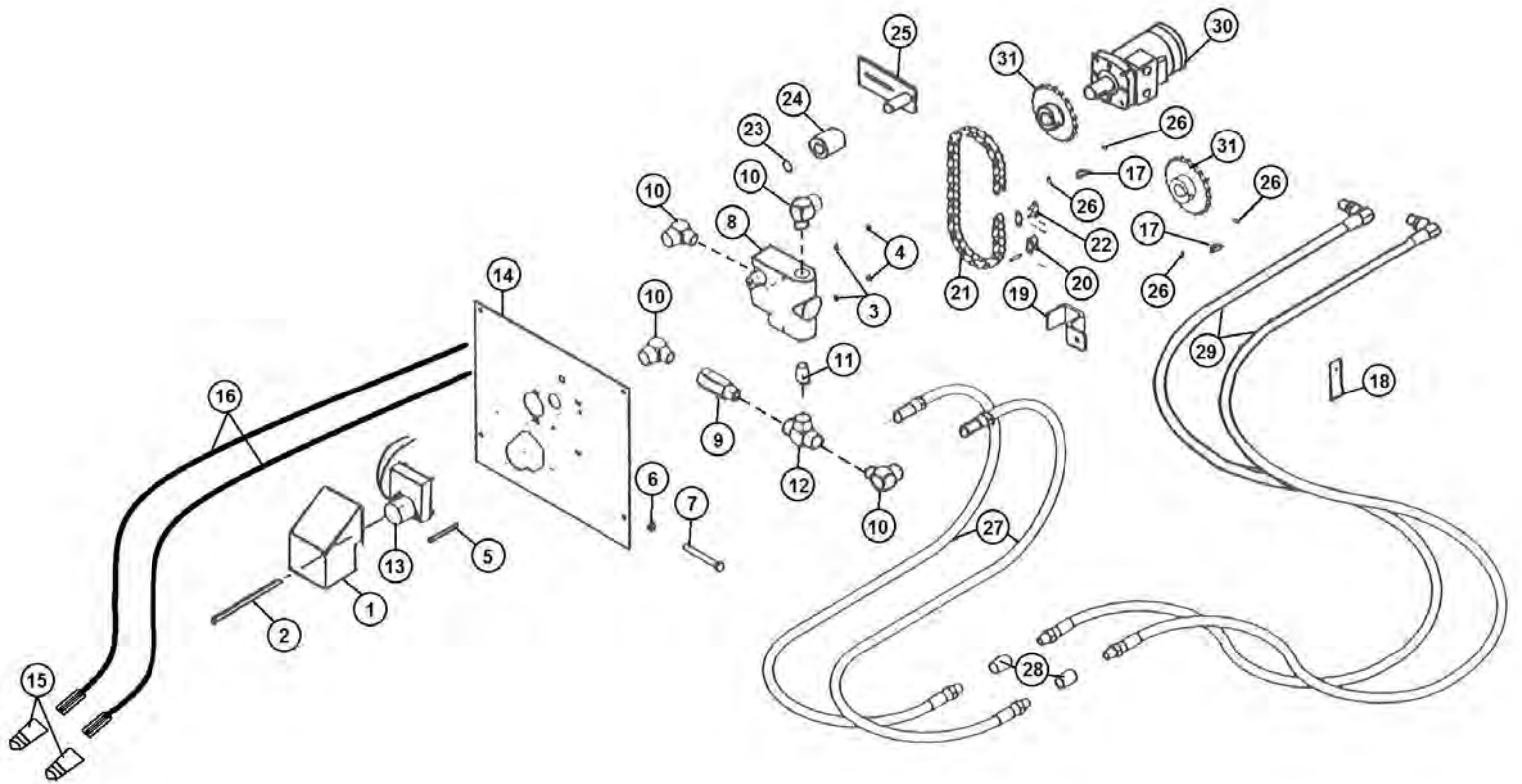

FIGURE 13

OPTIONAL ELECTRIC CONTROL FOR HYDRAULIC DRIVE

<u>ITEM</u>	<u>PART #</u>	<u>DESCRIPTION</u>
1.	43H1	MOTOR SHIELD HOLDER
2.	43H3	SHIELD BOLT
3.	YWLO08005	LOCKWASHER, 1/4"
4.	YNTL08005	TOP LOCK NUT, 1/4"
5.	YBCR08025	CARR. BOLT, 1/4"X2 1/2
6.	YNTL12005	TOP LOCK NUT, 3/8"
7.	43H5	FLOW INDICATOR
8.	DF15A	FLOW CONTROL
9.	DF18	CHECK VALVE
10.	HE58	ELBOW
11.	DF4	NIPPLE
12.	DF8	TEE
13.	16SV246	GEAR MOTOR
14.	23N133	CONTROL PANEL
15.	DWM205	MALE HYDRAULIC TIP
16.	23N309	HYDRAULIC HOSE
17.	5B10	1/4" x 1" WOODRUFF KEY
18.	23N117	HOSE HOLDER
19.	HE14	HOSE BRACKET
20.	X60	#50 CHAIN OFFSET
21.	23N131	#50 CHAIN 40 PITCHES
22.	X61	#50 CHAIN CONNECTOR
23.	10R32	SNAP RING
24.	23N238	ROLLER
25.	L10R35	TIGHTENER BRACKET TIGHTENER
26.	YSKP10010	SETSCREW(5/16"-18)
27.	HE12	HOSE EXTENSION
28.	31N23	3/8" COUPLING
29.	23N132	HYDRAULIC MOTOR HOSE
30.	DF1	HYDRAULIC MOTOR
31.	11S19	DRIVE SPROCKET

FIGURE 14

ELECTRIC CONTROL

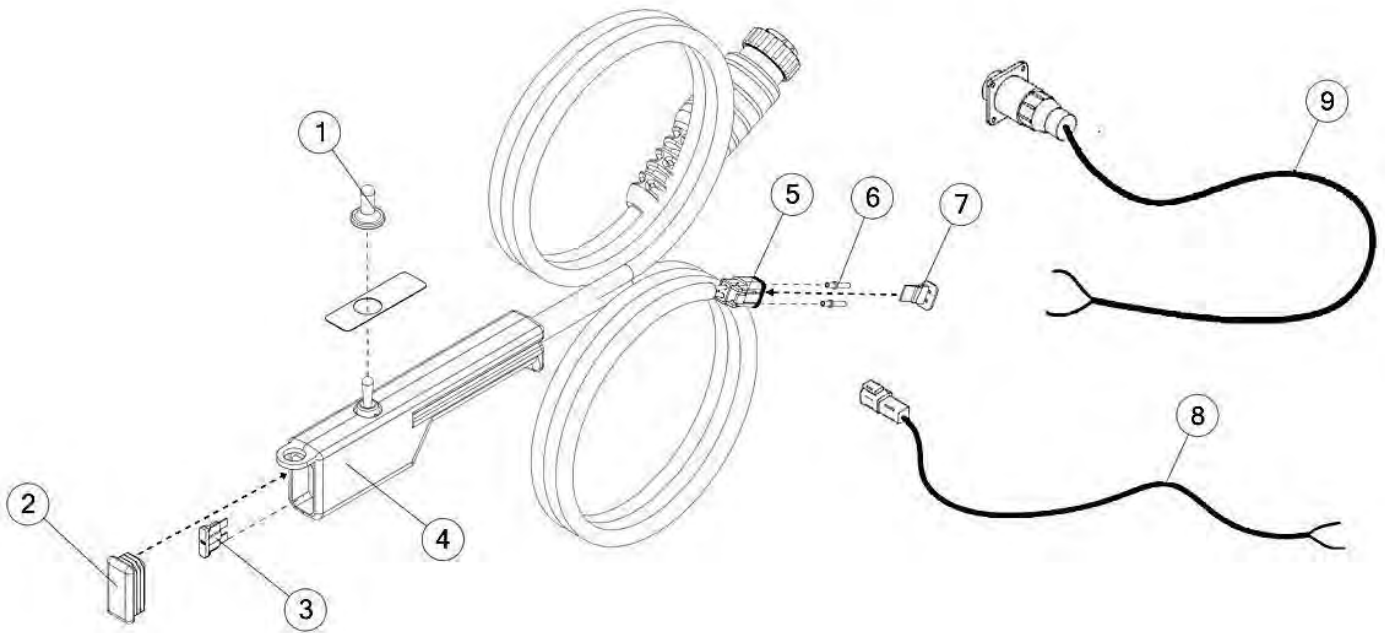

FIGURE 14
ELECTRIC CONTROL

<u>ITEM</u>	<u>QTY</u>	<u>PART #</u>	<u>DESCRIPTION</u>
1	1	16SV235	SWITCH BOOTS
2	1	61564	CAP
3	1	61597	FUSE, BLADE, 5AMP
4	1	63365	HAND CONTROLLER (ON-OFF-ON)
5	1	58790	DEUTSCH 2 PIN PLUG
6	2	56760	DEUTSCH SOCKET, SOLID, 14-16 GA.
7	1	58793	LOCKING WEDGE FOR DT06-2S CONNECTOR
8	1	56N134	SPREADER CONTROL CORD
9	1	16SV269	TRACTOR CONTROL CABLE

H&S MFG. CO.

products approved

for the

FEMA

SEAL OF QUALITY

